



# SAVING YOUR Treasures

*A Website about what you can do to protect and preserve the things of importance in your life*



**Gerald R. Ford Conservation Center**  
**Nebraska State Historical Society**  
1326 S. 32<sup>nd</sup> Street, Omaha, NE 68105 (402) 595-1180, Fax: (402) 595-1178  
[nshs.treasures@nebraska.gov](mailto:nshs.treasures@nebraska.gov)  
[www.nebraskahistory.org](http://www.nebraskahistory.org)

## MATting AND FRAMING

Proper matting and framing can help to protect your works of art on paper and other objects from deterioration due to changing relative humidity, extreme temperatures, light, handling, and other sources of damage.

### Matting

Conservators use a range of materials for matting that are inert and provide the proper level of strength and protection for each specific object. Manufacturers use terms such as “acid-free” and “archival” to indicate that mat board is safe to use but the terms are often misleading. The board may be acid-free at the time of manufacture but can still contain lignin, a natural occurring substance in wood that over time turns brown and becomes acidic. Choose a mat board that is free of acid, lignin, sizing that will become acidic, and has a neutral pH (pH 7). Alkaline additives in some mat board act as a buffer to neutralize acids that may develop over time.

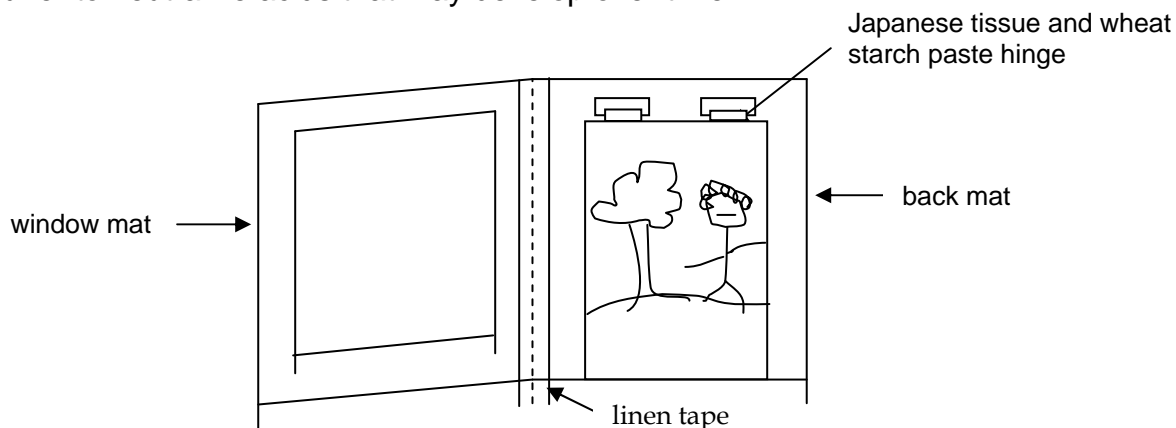

A mat for an object is a series of components constructed to fit and protect the object. It includes a back mat and window mat held together with a strip of linen tape (see figure above). The object is hinged to the back mat (not the window mat!) with hinges made of Japanese tissue paper and special wheat starch paste. The window mat allows the object to be seen while protecting it from handling while the back mat provides structural support for the object. The thickness of the mat board and the type of Japanese tissue

used for the hinge are selected based on the weight, size, and type of material of the object.

## Hinging

Hinges are placed along the top edges of the work of art. The two most common types of hinges are "T-hinges" and "V-hinges." These hinges are designed so that the object can be removed simply by cutting the hinge **between** the object and the back mat.

A T-hinge is generally used for works of art with definite margins. The bottom edge of a small piece of torn Japanese tissue paper is adhered to the edge of the back of the object leaving at least half of the hinge free. After drying, the free un-adhered portion of this hinge is adhered to the front top of the back mat. A second strip of Japanese tissue is then placed perpendicular across this hinge and is adhered to the back mat in the shape of a "T". See figure below.

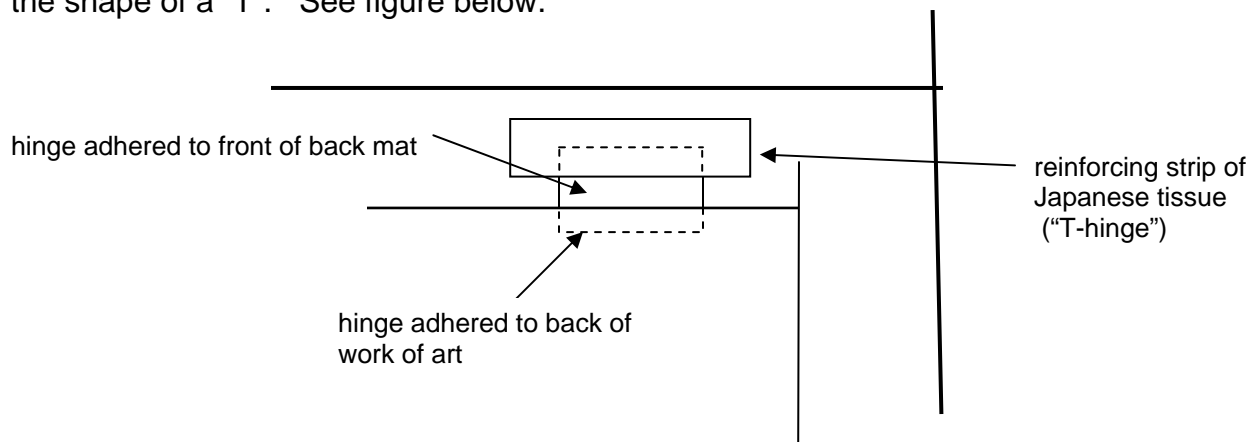

Hinges tucked out of site under an object are known as "V-hinges" or folded hinges. This type of hinge is used for works of art with no definite margins. They are used when an object is "floated" in the window, i.e. when the edges of the art are visible within the window. As with T-hinges, the bottom portion a small piece of torn Japanese tissue paper is adhered to the back mat, then folded over. After drying it is attached to the back of the work of art. See figure below. It is important to be sure that the top portion of the "V" hinge does not become adhered to the back mat. An isolating layer must be placed between the two sections of the "V" during the second gluing. For additional support a second strip of Japanese tissue may be placed perpendicular across the bottom portion of the hinge on the back mat.

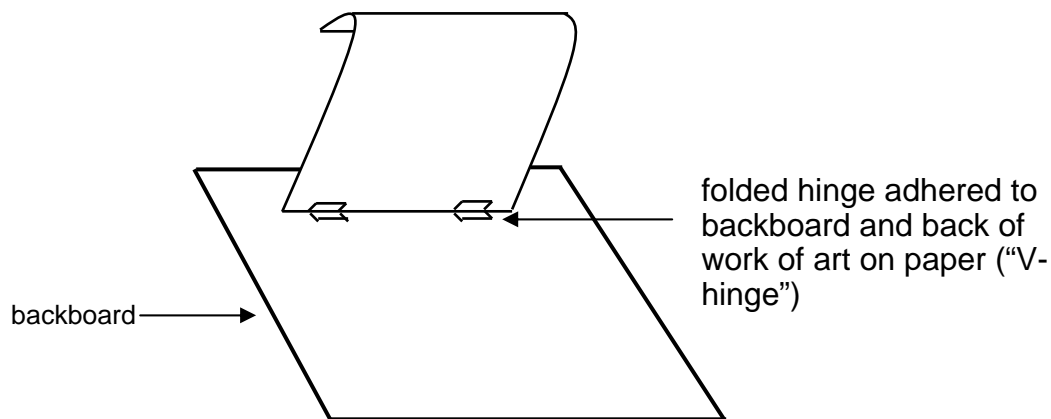

### Adhesives

Conservators look for adhesives that are strong and will hold for an indefinite period of time, do not discolor over time, and are reversible when the need arises to remove them. An adhesive that encompasses all these qualities is purified wheat starch paste. It is water soluble and readily removable even after years and is made from pure starch extracted from wheat flour. Do not use flour purchased at a store because it will not work and includes additives such as bleach. Wheat starch paste may be purchased from a conservation supplier in powder form. You must carefully follow the instructions for making wheat starch paste. If you do not want to make your own wheat starch paste, use Nori Ready-To-Use Wheat Starch Paste, which can be purchased from Conservation Resources International (See the Conservation Suppliers list).

### Framing

The most important thing to remember when framing your object is to not allow it to touch the glazing. This prevents the framed object from getting damp if moisture penetrates the frame and condensation occurs. The window mat creates a space between the item and the glazing. If your item does not have a window mat, place a spacer in the rabbet of the frame to create a space.

When deciding what glaze to use in framing your object, consider the advantages and disadvantages of acrylic and glass. Never use acrylic to glaze art with any powder media such as charcoal or pastels. Acrylic develops a static charge over time that attracts the powder media off the paper and onto the surface. Advantages for acrylic as a glaze are its scratch resistance, lightweight, it is unbreakable, and UV filtering. Advantages to glass are its usability with all types of media including charcoal and pastels and scratch resistance. Glass, however, is breakable and the larger the piece the heavier it is as well as the expense of purchasing UV filtered pieces.

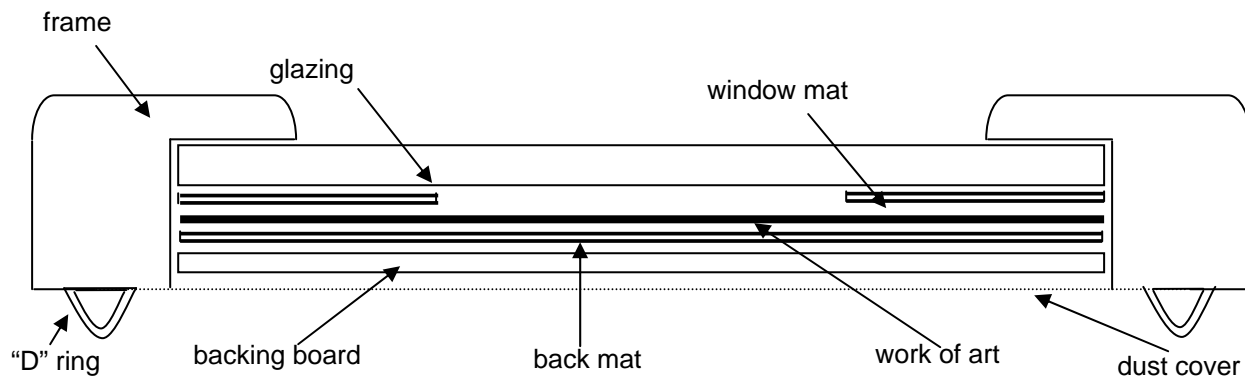

When selecting a frame, make sure it is deep enough to house the glazing, mat, dust cover, and backing board (see figure above for diagram of frame package). Backing board should be made of good quality board such as rag board or acid-free corrugated cardboard for additional support. Be sure to use a single piece of board cut to fit the inside frame dimension. To secure the backboard and matted object in the frame, conservators recommend non-rusting brass nails or turn-buttons. The frame package may then be sealed with a dust cover and linen tape.

Finally, make sure the fittings used for hanging your framed object are strong and secure. If a cord or wire is used, be sure to attach it to the frame itself. Remember to check the cord or wire tension before hanging it on the wall. You want to be sure that there is no strain on the frame that would cause the frame to break or fall. If screw eyes, hanging plates, or rings are used instead of cord or wire, attach them to the frame as well. Make sure these fasteners are strong enough to hold the weight of the object.

- [http://www.chicagoconservation.com/pages/tips\\_framing.htm](http://www.chicagoconservation.com/pages/tips_framing.htm)
- <http://www.conservationregister.com/guidancemountingframing.asp?id=3>
- <http://aic.stanford.edu/library/online/brochures/matt.html>
- <http://www.bishopmuseum.org/research/pdfs/cnsv-matsframes.pdf>
- <http://www.loc.gov/preserv/care/mat.html>

Recommendations in this website/pdf/video are provided as a public service for guidance only. Neither inclusion nor exclusion of products or providers constitutes endorsement or lack thereof. The Gerald R. Ford Conservation Center does not assume responsibility or liability, expressed or implied, for any resulting activities involving any collections or objects.